

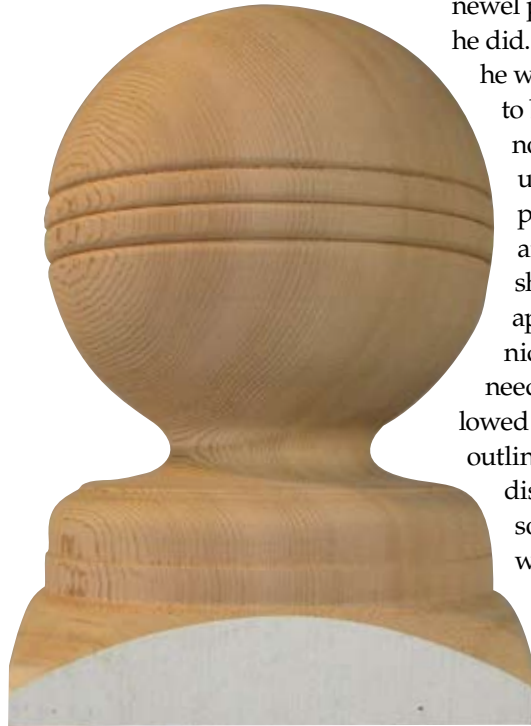

The original newel post cap and a new one.



Newel Post Caps

How to Approach a Turning Job

Jim Echter

An individual contacted me wanting to know if I could turn two newel post caps. We talked by phone about the project, and I asked if he had a sample he could show me. A few hours later, he stopped by my studio with a bag containing several rotted pieces of wood (*Photo 1*).

After looking at the pile of rubble, I asked if by any chance he had another newel post cap that was complete. Yes he did. We talked about what wood he wanted and the type of finish to be applied. At the time, I did not know if the caps were to be used on interior or exterior newel posts or if they were to be stained and varnished or painted. How should a turning job like this be approached—not just the techniques, but the analysis of what needs to be done and the steps followed to accomplish the task? I will outline how I analyzed this project, discuss the steps I took, and share some tips in the hope that you will be better prepared to tackle your own custom turning job.

Analyzing the job

The original cap was about 5½" (140mm) square at the base and about 8" (200mm) high. The new caps would need large-diameter timber or would have to be made from glued-up wood. The customer told me that he was going to replace the posts and asked if I could possibly use the wood from the old posts. I provided an estimate for labor, assuming I could use the old wood. The customer left and returned a few days later with an intact sample and the old posts. Better informed after our discussion, I was ready to make two new newel post caps.

First, I measured and drew a template of the original cap. This can be done on graph paper or by using a simple 2D CAD system, which is my



1 Original newel post cap, rotted.

preference. I used 80 lb. card stock for the template. Since this project had large-diameter balls on the top, I needed a template for checking the profile. I cut the template out of the card stock and printed another one so I could set my calipers and reference all the key dimensions (*Photo 2*).

I needed to cut into one of the old post that the customer provided, to see if the wood was sound and to try to identify what type of wood it was made from. When handling large timbers like this, I mark my dimensions and use the bandsaw instead of a pencil to mark the cut lines—saw marks are easier to see than pencil lines on some types of wood. I rotate the timber 90° and follow the cut line to cut the blank to length (*Photo 3*). The post turned out to be made of cedar, which meant that I would have to take precautions with the dust. A dust mask, a dust collector, and an air filter were all in order as cedar really makes me sneeze.

On a job like this, when the blank may not be perfectly square, I find the centers on the ends employing two methods. First, I mark corner to corner with a pencil, the method used by most turners. I also use a small try-square to mark lines parallel and equidistant to the sides and near the center to create a

small box. The centers are then located using an awl (*Photo 4*).

Mounting to the lathe

A major decision point for a project like this is how to mount the turning blank to the lathe. Since this project has a tenon on the bottom and a relatively thin cove section, I decide to turn the majority of the project between centers and just finish the very top of the ball with the blank mounted in a 4-jaw chuck.

The original post cap used a 2" (50mm)-diameter tenon on the bottom to locate it on the top of the post. Next to that there is a square section that eventually gets rounded over on top to make the transition to the round sections of the cap. To mark these elements, draw lines on the blank to indicate the top and bottom of the square section. Since the wood is cedar, I knew it would be prone to chip out.

I also knew that because of the large diameter, the square section had the potential to be a real knuckle buster, so I wrapped the square section with red painters' tape. The tape helps prevent chip out on the square areas, as well as providing a visible warning to stay away from the knuckle-busting corners (*Photo 5*).

Begin turning

I always like to get the feel for each piece of wood so I begin making some simple cuts in a waste area. In this case, the waste area is on the bottom where the tenon is located. I begin to turn the bottom and the tenon. For the square shoulder, I use a skew chisel to step over into the flat shoulder. I start about 3/4" (20mm) to the left and make my cuts with the right bevel of the skew chisel parallel to the shoulder (*Photo 6*).

I make these shoulder cuts at a fairly high rpm, as I get less bounce with ▶

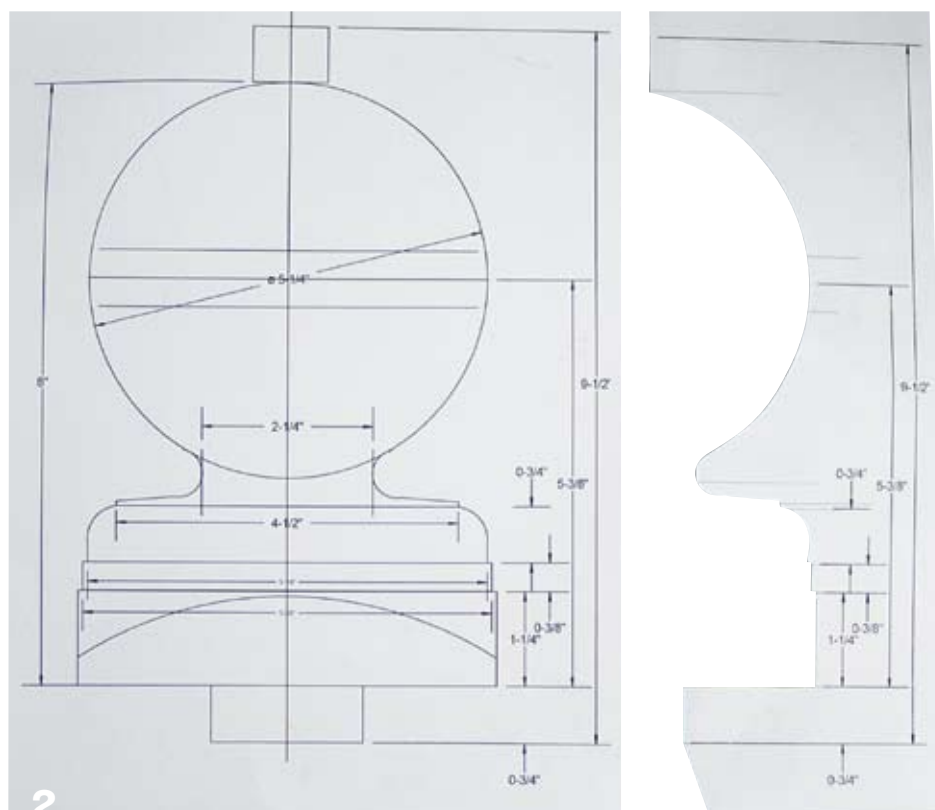

2 Drawing and template cutout.



3
Follow the marking-cut line to cut the post to length using a bandsaw.



4
Use an X and parallel, equidistant lines drawn near the center to locate the center point.



5
Affix red painters' tape to the square shoulders to help reduce tear out of the wood and to provide a warning sign.

the tool and achieve a smoother finish with less tear out.

Once the shoulder cut is finished, proceed to turning the tenon (*Photo 7*). Begin by using a parting tool to size the very end of the tenon. Be careful, as the parting tool will be substantially extending out over the toolrest. My hand holds the tool handle on the very end to provide as much leverage as possible. Cut the tenon to just slightly oversized. Measure just the end to the 2" (50mm) diameter using calipers *with the lathe off*. It is just too dangerous to take this measurement using calipers with the blank spinning—the cedar is rough and you can easily catch the caliper on the square section (*Photo 8*). Once the end is sized, turn the rest of the tenon to that same diameter.

To complete the bottom section of the post cap there are two more steps, both important. The first is to slightly undercut the bottom of the square section. This is to ensure that the cap will fit tightly to the top of the post. The second step is to put a groove about 3/8" (10mm) up the tenon. This groove will be used later when the blank is moved to a 4-jaw chuck. (The tiny teeth on my Nova chuck fit into this groove, and because I will only take a light finishing cut, a shoulder isn't needed.)

The groove also holds excess glue when the cap is installed onto the newel post. Slightly round over the bottom of the tenon to make it easier to insert into the posthole. Little details like these are what the customers appreciate (*Photo 9*).

Turn the top section

Now it's time to turn the top section of the post cap. Turn a square should-

er the same way as before; however, this time step from the right to the left up to the shoulder. Once you score completely around the blank, then it is time to rough turn the top section. You can use your favorite spindle-roughing gouge or swept-back bowl gouge (*Photo 10*).

I use a skew chisel to smooth this section after turning it to a cylinder



6
Cut with the skew chisel's right bevel parallel to the shoulder to create a square shoulder.



7
The shoulder is finished and it's time to turn the tenon.



8
Use calipers to size the tenon. Make sure the lathe is off when measuring next to a square shoulder such as this.



9
The tenon is finished and slightly rounded off at the bottom and there is a slight undercut to the shoulder.

so that I can easily mark my layout lines. Again, watch out for the square knuckle-busting section.

Using the template, mark all the transition points and carry the pencil marks around the blank (*Photo 11*).

Proceed to turn the post cap in the same manner as any spindle project. Use the parting tool to cut to all the key dimensions (slightly oversized) (*Photo 12*). Rough turn the top tenon to about a 1" (25mm) diameter. Rough turn the ball shape and the large cove. I like to use detail gouges for these cuts. The added thickness of detail gouges helps eliminate tool vibrations. Round over the corners of the top of the square section using a skew chisel or a detail gouge (*Photo 13*). This cut is mostly in air until you get to solid wood.

Using the template and the drawing, set your calipers to actual dimension and part to all the key transition dimensions. Then make all your finish cuts, checking the profile with the template as you go. Very minor changes can have a huge visual impact on the finished product so take your time and make very light cuts (*Photo 14*).

Once you are satisfied with the shape, add the decorative beads around the center of the ball. Sand the base, coves, and the ball. Because this cap will be used on an exterior railing, it is going to be painted. For painted projects, I only sand to 150 grit. Any finer than that is not only a waste of time, but it makes the surface too smooth for paint to adhere (which would not please the customer).

It is now time to remount the cap in a 4-jaw chuck (*Photo 15*). Use the tailstock center to ensure it is running true. Turn away the top tenon (*Photo 16*), check the profile one more time, and finish-sand the top of the ball.



10
Rough out the top section of the newel post cap.

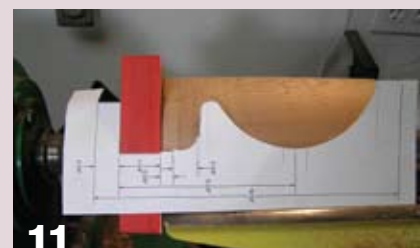

11
Use the cutout template to mark where each element transition line will be drawn.



12
Layout lines are marked and the first key dimension is created using a parting tool.



13
Round over the square shoulder.



14
The cap is rough turned and ready for decorative beads and sanding.



15
Remount the tenon of the newel post cap into a 4-jaw chuck using the turned groove as a marker for the teeth of the chuck.



16
Cut away the tenon from the top part of the newel post and sand that area.

The second newel cap

Now you can start on the second one. The real challenge comes with making two that look alike, but you can do it now that you have developed all the steps and processes that let you break this project into little chunks.

When you are all done, step back, admire your efforts, and call your happy customer!

Jim Echter lives near Rochester, NY. He is a professional turner who specializes in making tools for fiber artists, turning custom architectural pieces, and teaching all aspects of woodturning. Jim is the current President of the Finger Lakes Wood Turners chapter of the AAW, a position he has held before. Contact him at jim@truecreations.biz or visit his website at truecreations.biz.